

A DESIGN AND PERFORMANCE ANALYSIS TOOL FOR SUPERCONDUCTING RF SYSTEMS

T. Schilcher, S.N. Simrock, DESY, Notkestr. 85, 22603 Hamburg, Germany
L. Merminga, D.X. Wang, TJNAF, 12000 Jefferson Avenue, Newport News, VA 23606

Abstract

Superconducting rf systems are usually operated with continuous rf power or with rf pulse lengths exceeding 1 ms to maximize the overall wall plug power efficiency. Typical examples are CEBAF at the Thomas Jefferson National Accelerator Facility (Jefferson Lab) and the TESLA Test Facility at DESY. The long pulses allow for effective application of feedback to stabilize the accelerating field in presence of microphonics, Lorentz force detuning, and fluctuations of the beam current.

In this paper we describe a set of tools to be used with MATLAB and SIMULINK, which allow to analyse the quality of field regulation for a given design. The tools include models for the cavities, the rf power source, the beam, sources of field perturbations, and the rf feedback system. The rf control relevant electrical and mechanical characteristics of the cavity are described in form of time-varying state space models. The power source is modelled as a current generator and includes saturation characteristics and noise. An arbitrary time structure can be imposed on the beam current to reflect a macro-pulse structure and bunch charge fluctuations. For rf feedback several schemes can be selected: Traditional amplitude and phase control as well as I/Q control. The choices for the feedback controller include analog or digital approaches and various choices of frequency response. Feed forward can be added to further suppress repetitive errors. The results of a performance analysis of the CEBAF and the TESLA Linac rf system using these tools are presented.

2 INTRODUCTION

In the field of accelerator physics many sophisticated computer simulation codes have been developed in the past decades. They are mainly used to verify and optimize designs for the beam transport system but also codes for accelerator components such as magnets, rf cavities, and electron sources are readily available. There is however no sufficiently generic simulation code for the design of rf control systems available [1].

The authors of this paper have started the project of developing a generic rf system simulation code with emphasis on superconducting rf systems. This tool is to be used for the design and performance assessment of new or existing rf systems. The ultimate goal is a tool which supports on-line diagnostics during the commissioning phase and during routine operation of the rf system.

The tools make use of the high level programming

language MATLAB and SIMULINK which are available at most accelerator facilities. MATLAB provides a natural environment for analysis, algorithm prototyping, and application development which is complemented with SIMULINK's graphical user interface for construction of block diagram models using "drag-and-drop" operations. The rf system design and performance analysis tool is freely available via world wide web at "http://tesla.desy.de/rf_model/". The authors appreciate feedback from potential users of this software on their specific needs so that the tool can be made more universal. Presently the models have been used to study the rf systems at Jefferson Lab [2], the rf system for the TESLA Test Facility [3], the superconducting option for ESS and the recirculating linacs for the muon-collider.

3 CONCEPTUAL DESIGN

The concept of the rf system design tool is based on a combination of an interactive user interface with graphical blocks for rf sub-systems and initialization files for the

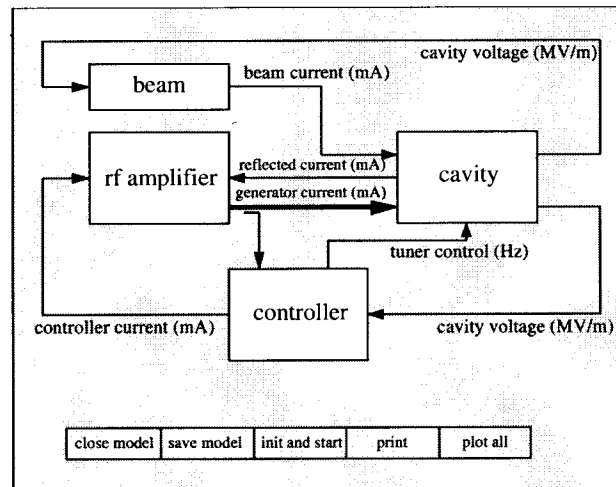

Figure 1: RF Sub-systems and interconnections at level 1 system parameters. The key features of the rf system design tool are:

- main blocks for major rf sub-systems
- fixed interconnection structure between sub-systems
- well defined interface between sub-systems
- multi-level tree structure within sub-systems
- separate initialization files for sub-system parameters

The main blocks and interconnection structure are shown in Figure 1. The rf amplifier which is modelled as a current source drives the rf cavity. The beam current is

superimposed to the generator current with opposite phase. The cavity blocks calculates the response of the cavity to the two driving currents. The output of the cavity is the time-varying accelerating field in units of MV/m. In the controller block, the cavity gradient and phase are compared to the desired setpoints and the amplified error signal controls the generator current. Provision has been made to allow for cavity-beam-cavity interaction which is important for circular machines and recirculating, energy-recovering linacs.

3.1 Tree Structure

From the main panel the user can access the sub-systems. The controller block consists of the feed forward, the feedback, and the tuner sub-system control blocks which appear on level 3. The level below the sub-system level is user defined and it is planned to provide an extensive library of user defined blocks which describe actual rf system components.

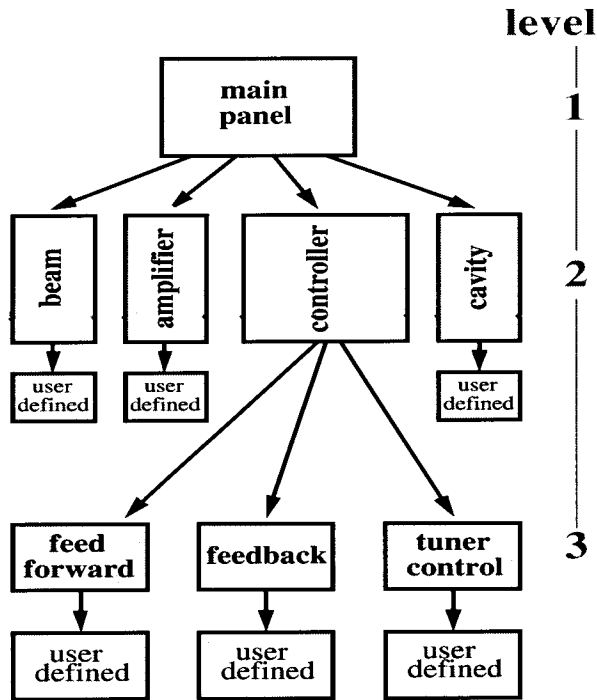

Figure 2: Tree Structure of the RF Simulation Tool

3.2 Files and Nomenclature

The rf system model consists of several m-files for the graphical blocks and the initialization files. The filenames include the project name and the block name. The following blocks must exist for a complete model:

- project.m
- project_cavity.m & project_cavity_init.m
- project_amplifier.m & project_amplifier_init.m
- project_feedforward.m & project_feedforward_init.m
- project_feedback.m & project_feedback_init.m
- project_tuner.m & project_tuner.m
- project_beam.m & project_beam_init.m

- project_plot.m

It is possible to mix blocks from several projects but it is important that the block name and the corresponding initialization file match to ensure the correct setting of parameters.

4 RF SUB-SYSTEM BLOCKS

The rf sub-systems contain user-defined blocks with accompanying initialization files. These rf system specific blocks are added to a library which can be exchanged between various users since the interface between the sub-systems is well defined.

4.1 Beam

The beam can be modelled with arbitrary time-varying amplitude and phase as specified in a table. It is also possible to use pulse generators for a repetitive pulse structure and add a noise source to simulate bunch charge fluctuations. The beam library contains blocks for the cw beam at Jefferson Lab and the pulsed beam for injector I and injector II at the TESLA Test Facility.

4.2 Amplifier

It is possible use the measured non-linear characteristics of a klystron to create an input-output mapping table. The present klystron library contains a linear amplifier with a hard power limit.

4.3 Cavity

The use of superconducting cavities implies that Lorentz Force detuning and microphonics are included in the model. The state space representation of a cavity including Lorentz Force detuning is given by:

$$\begin{bmatrix} \dot{v}_r \\ \dot{v}_i \\ \Delta\omega \end{bmatrix} = \begin{bmatrix} -\omega_{1/2} & -(\Delta\omega + \Delta\omega_T) & 0 \\ \Delta\omega + \Delta\omega_T & -\omega_{1/2} & 0 \\ \frac{2\pi \cdot K}{\tau_m} v_r & \frac{2\pi \cdot K}{\tau_m} v_i & -\frac{1}{\tau_m} \end{bmatrix} \begin{bmatrix} v_r \\ v_i \\ \Delta\omega \end{bmatrix} + \frac{R\omega_{rf}}{2Q} \begin{bmatrix} 1 & 0 \\ 0 & 1 \\ 0 & 0 \end{bmatrix} \begin{bmatrix} I_r \\ I_i \end{bmatrix}$$

where v_r, v_i : real and imaginary component of the cavity voltage ,
 I_r, I_i : real and imaginary component of the total current (generator + beam)
 $\Delta\omega + \Delta\omega_T = \omega_0 - \omega_{rf}$, $\omega_0 = \omega_0(t)$: resonance frequency of the cavity ,
 ω_{rf} : operating frequency , $\omega_{1/2} = \omega_{rf}/(2Q)$: half width of resonance ,
 $\Delta\omega_T$: detuning by frequency tuner , τ_m : mechanical time constant ,
 K : Lorentz force detuning constant .

The cavity library supplies a model for the cavities at Jefferson Lab and the TESLA Test Facility. For the TTF rf system a model of 8 cavities with different parameters including calibration errors for incident wave and vector-sum has been developed.

4.4 Controller

The Controller is composed of the subsystems feedback, feed forward, and tuner control. The feedback library includes model for amplitude and phase control and IQ control. It is possible to mix analog and digital design. In the digital design the possibility of the use of state

estimators is foreseen.

5 SELECTED SIMULATION RESULTS

5.1 TESLA Test Facility

RF System modelling is of great importance for the design of the TTF rf system since the vector-sum of 8 (later 16) cavities will be controlled in presence of Lorentz Force detuning, microphonics, and heavy beam loading. The model allows to predict the performance of the digital rf feedback system [3] in presence of parameter variations. The simulation results in Figure 3 show an attempt to operate the cavities at different gradient by variation of the loaded Qs. The simulation allows to monitor the maximum field in each cavity and optimize the system to operate close to the maximum operable gradients of each cavity.

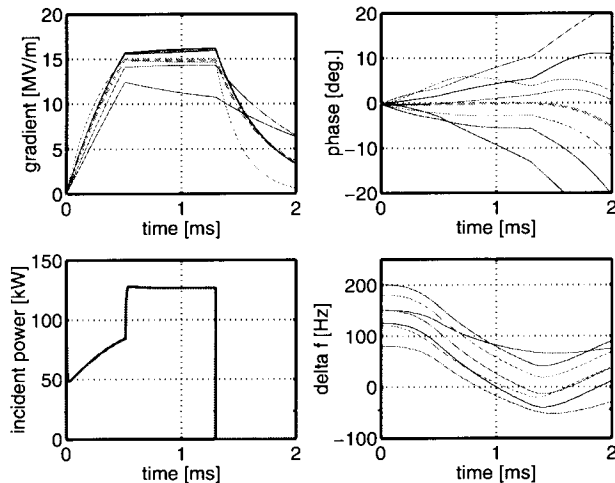

Figure 3: Operation of the TTF cavities at different gradients with different loaded Q and with 8mA of beam loading. The vector-sum is regulated to 15 MV/m.

5.2 Jefferson FEL RF System

A high average power Free-Electron Laser (FEL) is presently under construction at Jefferson Lab. The driver accelerator of the first phase of the FEL program, is a recirculating energy-recovering 42 MeV, 5mA cw superconducting rf electron accelerator.

The start up of the beam in the FEL is an interesting example of rf optimization as it must be done in a way that leaves the rf stable and robust, must be compatible with transport of space charge (and lack therefore) dominated beams and must be compatible with recirculation and energy recovery.

We have examined three different start up scenarios and we present here simulation results from one of them. In this scenario the average beam current is increased from 0 to 5 mA by first increasing the repetition frequency in factors of 2 at constant charge per bunch of 35 pC. When the beam repetition frequency reaches the operating frequency of 37 MHz, resulting in an average current of 1.3 mA, the current

is further increased by linearly increasing the charge per bunch from 35 pC to 135 pC, for a total of 5 mA. Figure 4 displays beam current, amplitude and phase of the cavity fields as function of time, for the injector cavities with no energy recovery, and the linac cavities with energy recovery.

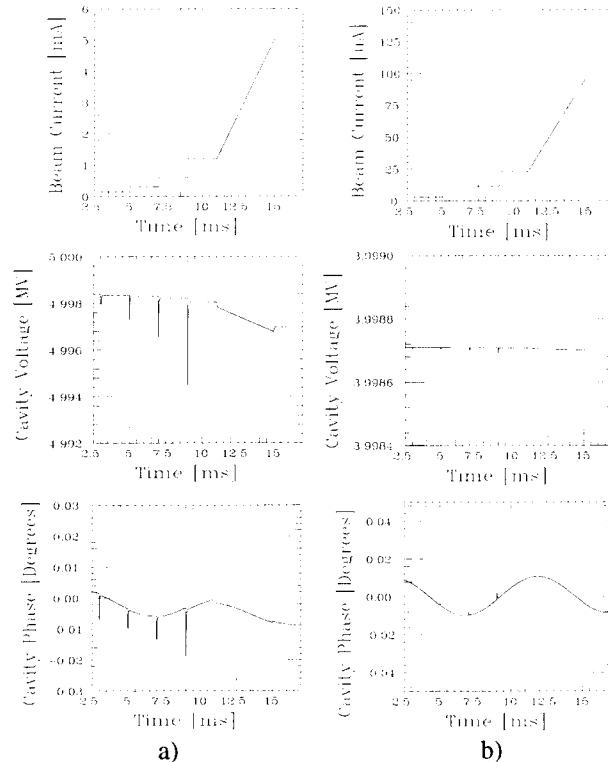

Figure 4: Jefferson Lab FEL RF system startup response in a) injector and b) linac.

6 CONCLUSION

An rf system design and performance analysis tool has been developed as a joint effort between DESY and Jefferson Lab. It has been successfully used to predict the performance of various rf system. The generic design of this tool allows its use for the simulation of a variety of different rf system with focus on superconducting cavities and relativistic beams. A well defined interface will allow the exchange of user defined sub-system blocks with the according initialization files among different users. This hopefully will help to reduce redundant efforts in rf system modelling in the future.

7 ACKNOWLEDGEMENTS

We gratefully acknowledge numerous helpful discussion with J.D. Delayen, L. Doolittle, and A. Gamp.

8 REFERENCES

- [1] R. A. Jameson, EPAC 96, pp. 210-212
- [2] L. Merminga et. al., EPAC 96, pp. 2079-2081
- [3] S.N. Simrock et al., EPAC 96, pp. 349-351